

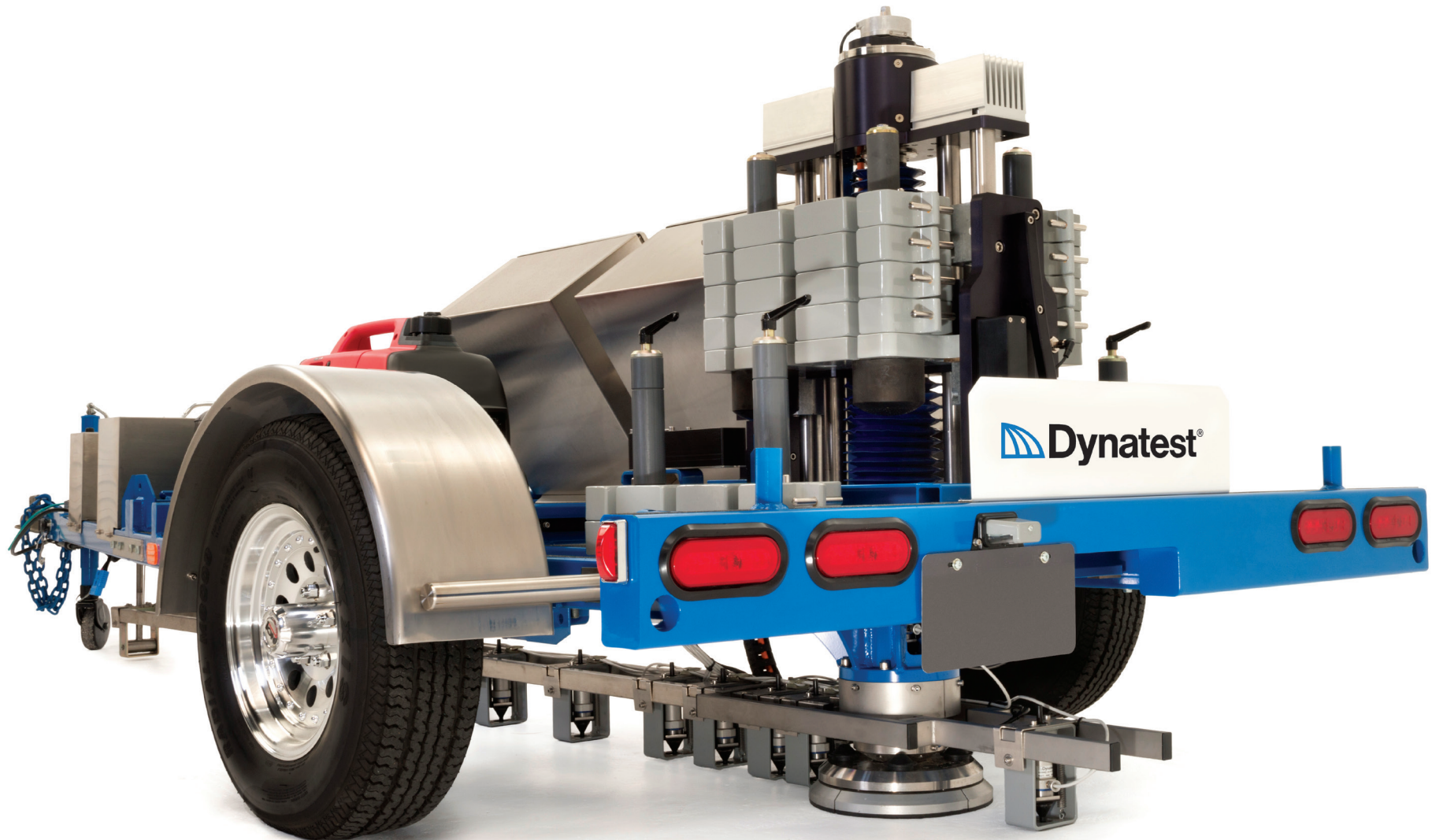

## 8012 FAST FALLING WEIGHT DEFLECTOMETER (FastFWD)



Dynatest, the original commercial developer of the Falling Weight Deflectometer (FWD), introduces the next generation FWD—the Dynatest FastFWD Model 8012.

The FastFWD is designed to impart a load pulse to the pavement surface simulating the load produced by a rolling vehicle wheel. The load is produced by dropping a large weight on top of a set of rubber buffers on a bracket connected to a circular load plate. A load cell mounted on top of the plate measures the imparted load. Deflection sensors (geophones) mounted in and radially from the center of the load plate measure the deformation of the pavement in response to the load. The post

processing software, Dynatest ELMOD (Evaluation of layer Moduli and Overlay Design) can be used to back-calculate the pavement layer moduli based on the impact load and surface deflection basin. The results can effectively be used for the evaluation of pavement structural condition and overlay design based on empirical or mechanistic-empirical pavement design guides.

The FastFWD data can also be used to calculate the degree of load transfer between adjacent concrete slabs, and to detect voids under slabs in rigid pavements.



## ■ KEY FEATURES

Nondestructive structural testing device

Ideal for fast, comprehensive testing for mechanistic-empirical analysis and design

Wide loading range—4–120 kN; suitable for testing a variety of paved and unpaved roadways, parking lots and some airfield surfaces

Excellent repeatability Single person operation Quiet operation

Accommodating up to 15 deflection sensors AASHTO R32-11 calibration protocol compliant Passes TRL (UK) correlation trials

## ■ STANDARD EQUIPMENT

Four segmented loading plate with swivel accommodates uneven or rutted pavement surfaces

Air/Pavement Temperature Sensors

Distance Measuring Instrument (DMI)

On board generator for standalone operation

## ■ ADVANTAGES

A single direct drive, 3-phase torque motor and ball screw assembly drives the new system replacing the hydraulic system in hydraulic FWD

Very fast—up to 160 test points per hour

8002 FWD's can be upgraded to the new

FastFWD Model 8012 system

Less maintenance costs—no hydraulic system

Less impact due to reduced survey time

## ■ AVAILABLE UPGRADE OPTIONS

Folding trailer for ease of shipment

Global Positioning System (GPS)

Additional deflection sensors (up to 15)

Camera system for plate location or photo-logging

Towing vehicle

Trailer cover (hard or soft options)

Trailer mounted light(s) or strobe(s)

Rear or Rear and Transverse Sensor Extension Bars

GSSI Ground Penetrating Radar

Spare parts kit

Tool kit

## ■ FWDWin FIELD SOFTWARE

FWDWin intuitive and user -friendly software facilitates data collection in the field

It supports multiple languages, stores FastFWD data in Access (.mdb) databases for further processing and generates the following legacy formats: .fwd, .f25, .PDDX

Real-time plotting of the surface moduli along the test sections

## ■ ELMOD SOFTWARE

### Evaluation of Layer Moduli and Overlay Design

Evaluation of Layer Moduli and Overlay Design

Dynatest's ELMOD software may be used for the analysis and design of flexible, rigid, and composite pavements

Allows quick data reduction and analysis of FastFWD load/deflection measurements

Capable of backcalculation of the layer moduli, for a typical drop sequence, in less than a second

Fast calculation of the seasonally adjusted moduli, residual life of the pavement, and required overlay thickness for a given service life

For maintenance and rehabilitation (M&R), the LCCA (Life Cycle Cost Analysis) module allows the user to select the optimum M&R solution for a pavement section according to cost/benefit ratios

For analysis of airfield pavements, the optional PCN module calculates PCN in accordance with the ACN/PCN method, as described in the ICAO and FAA design manuals

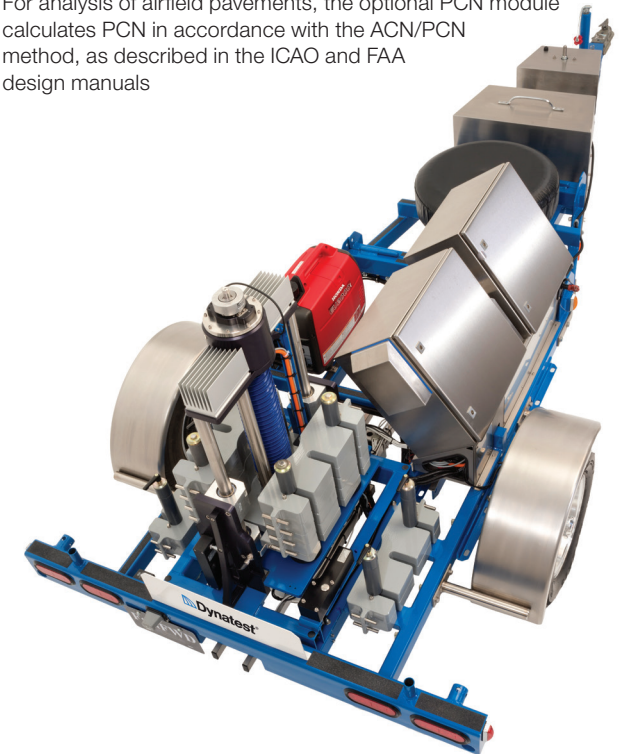

Feet between test point		50	250	500	1000
Typical four drop production	FastFWD total points per eight hours	1312	1032	904	680
	Current FWD total points per eight hours	736	640	584	488
	<b>% Improvement</b>	<b>78%</b>	<b>61%</b>	<b>55%</b>	<b>39%</b>
LTPP nineteen drop test	FastFWD total points per eight hours	688	600	552	464
	Current FWD total points per eight hours	240	224	216	200
	<b>% Improvement</b>	<b>187%</b>	<b>168%</b>	<b>156%</b>	<b>132%</b>